

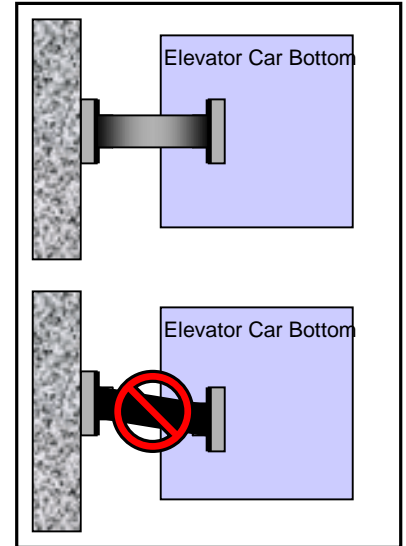

**IMPORTANT!** This procedure highlights only the part of the steel-supported flat cable installation procedure associated with the FCSD-S bracket. This document is intended to be used as a guide to installing flat traveling cable with the FCSD-S bracket only and does not contain all-inclusive installation procedures for flat traveling cable.

**Step 1** **Mark drill holes** for the FCSD-S brackets on the elevator car and at the mid-hoistway hang point, so the brackets and cable can be properly aligned (as shown to the right).

See **“Forming the Loop”** to help establish the appropriate distance between the brackets.



**Step 2** **Install the FCSD-S brackets** so that the semi-circular section is upright.

The FCSD-S bracket supports a maximum weight of 1500 lbs/682 kg.

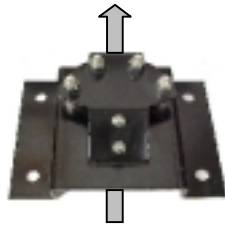

The maximum clearance for flat traveling cable to pass under the FCSD-S bracket is  $\frac{5}{8}$  inch · 16mm.

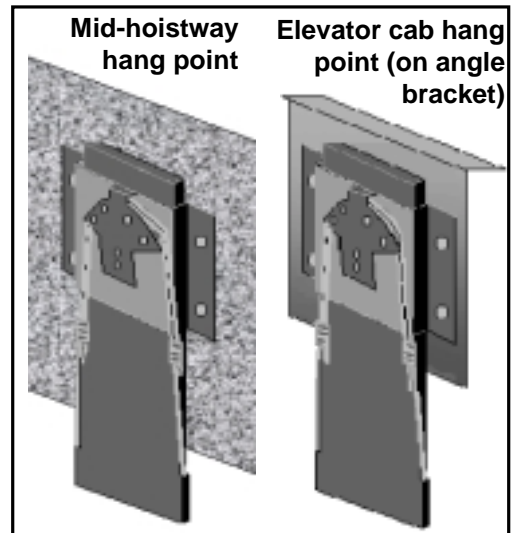

**Additional cables** may be attached to the FCSD-S bracket. Contact Draka EP's Applications Engineering Dept. at 877-372-5237 or +1 252-972-6000.

When **installing more than one set of FCSD-S brackets**, ensure there are at least 2-4 inches · 55-105 mm between the brackets.

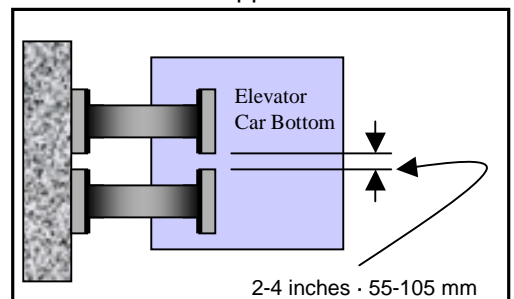



**Step 3** Strip the jacket on the narrow edges of each end of the cable, being careful not to nick the underlying conductors.

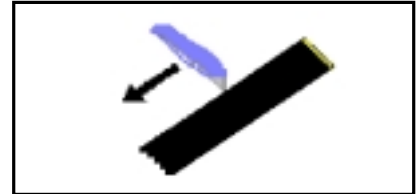

Pull the steel support members away from the cable end until a minimum length of 24 inches · 610 mm is free.

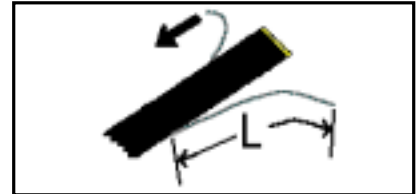

Place ferrules over support members.

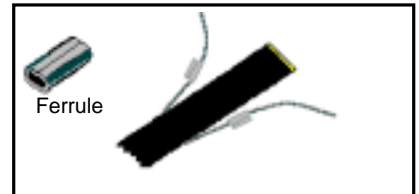

Pass one support member through the FCSD-S bracket and the ferrule on the opposite support member, then crimp the ferrule in three (3) places with a swaging tool. Repeat this step for the other support member.

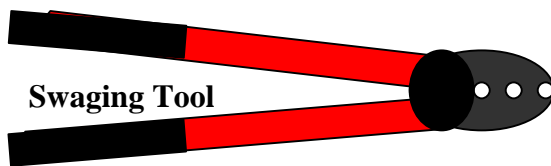
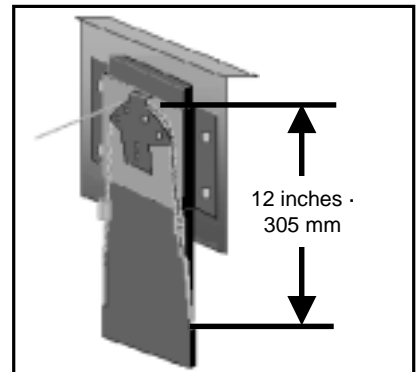

Swaging Tool

### Forming The Loop

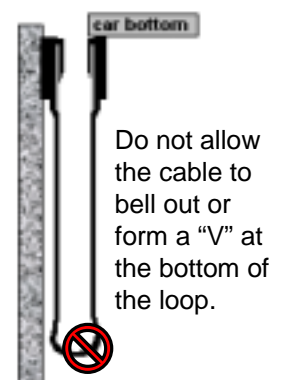
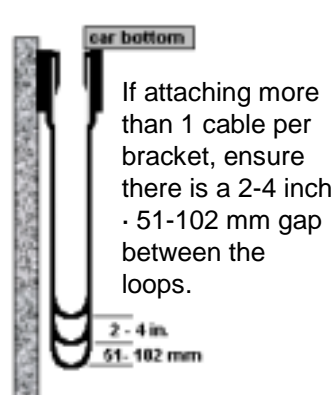
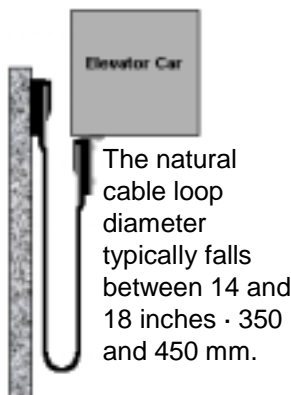

Draka Elevator Products, Inc. reserves the right to improve enhance, and modify the features and specifications of Draka Elevator Products, Inc. products without prior notification.

Draka Elevator Products and the Draka Globe Design are trademarks of Draka Elevator Products, Inc.

© Draka Elevator Products, Inc.  
All Rights Reserved  
October 2002

**Draka Elevator Products, Inc.**  
2151 North Church Street  
P.O. Box 400  
Rocky Mount, NC 27804  
252-972-6000  
877-DRAKA-EP 877.372.5237  
Fax: 252.972.6001