



The Shallow SwayLess Sway Reduction Device (WFDD-50L) for short or shallow pits less than six feet in depth provides the superior sway reduction performance of rollers at a much lower height. The Shallow SwayLess, WFDD-50L, device has adjustable arms so that the roller placement can be optimized for each installation and adjusted as necessary for Steadi-Flex cable length adjustments.

ASSEMBLY

ASSEMBLY TIME – Less than 10 minutes

Assemble each vertical stand by

1. placing 4 channel nuts in a 32 1/4" strut
2. place strut in a base plate
3. and fasten the strut with two 1/2" x 1" bolts

REPEAT for 2nd Stand

Figure 1 – Vertical Stand Assembly

TOOLS NEEDED:

- 3/4" Socket wrench
- 13mm Socket wrench

For Installation

- Rotary Hammer w/ 1/2" bit

Place a channel nut in the center of the two 60" and two 16" struts.

Figure 2 – Channel Nut insertion

Fasten the two 60" struts together by attaching rollers in the end holes on the struts. Repeat for the two 16" struts.

Figure 3 – Roller Arms Bracket Assembly

Fasten the 16" roller arm bracket onto the middle portion of the vertical stands using two no-twist square washers, two 1/2" x 2 1/2" bolts and the channel nuts already in the vertical stands.

Figure 4 – Roller Arm Assembly

INSTALLATION (on an already installed compensating cable)

INSTALLATION TIME – Less than 20 minutes

Place the cable loop through the 60" roller arm

Figure 5 – Cable in rollers

Pull the cable loop to one side and place the bottom portion of the device over the cable loop.

Figure 6 – Cable in Shallow SwayLess

Attach the 60" roller arm to the upper portion of the vertical stands using 1/2" x 2 1/2" bolts and flat, square no-twist washers.

Ensure that the cable is inside the 60" roller arm and that the 16" roller arm is inside the cable's loop.

Figure 7 – Final Assembly

Center the cable in the device

End View

Fig 8 – Placement

With the cable centered in the device, center the vertical stands with the bottommost part of the cable's loop.

Figure 9 – Device Placement

Once the device is in its correct position, mark holes on the pit floor using the base plate holes as a guide.

Figure 10 – Mark Anchor Points

Drill four 1/2" holes, 2 1/4" inches deep. Clear dust from hole. Hammer the wedge anchors into the holes.

Place the rubber pads over the anchors

Figure 11 – Drilling Anchor Holes

Fasten the Shallow SwayLess to the floor using 1/2" flat washers and hex nuts.

Figure 12 – Final Installation

DEP-WFDD-50L/001

Draka Elevator Products, Inc.
2151 North Church Street
P.O. Box 400
Rocky Mount, NC 27804
252-972-6000
877-DRAKA-EP (877-372-5237)
Fax: 252-972-6001

Shallow SwayLess, Whisper-Flex, Draka Elevator Products and the Draka Globe Design are trademarks of Draka Elevator Products, Inc.

© Draka Elevator Products, Inc.
All Rights Reserved
January 2005



FINAL ADJUSTMENTS

ADJUSTMENT TIME – 5 minutes

HEIGHT ADJUSTMENT

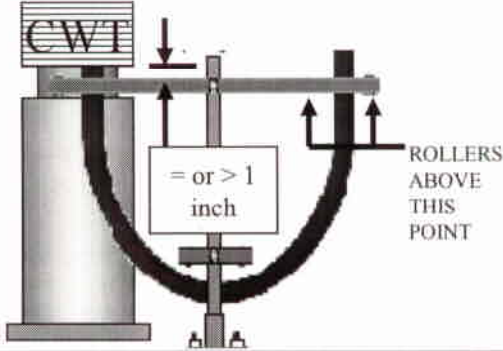

- Place the uppermost roller arm at the highest point possible on the vertical stands. At a minimum, the uppermost rollers should be above the curvature of the loop. The roller arm can be moved by loosening the two bolts fastening it to the vertical stands and pushing on them while adjusting the roller arm's height.
- If the vertical stands are within a one-inch clearance with any part of the car, then the vertical stands can be cut down to a shorter length in order to obtain the one-inch vertical or horizontal clearance.

IMPORTANT NOTE: THERE SHOULD BE AT LEAST ONE-INCH CLEARANCE BETWEEN THE SHALLOW SWAYLESS AND ANY PART OF THE COUNTERWEIGHT AND/OR CAR WHEN THEY ARE RESTING ON THEIR FULLY COMPRESSED BUFFERS.

LOWER ROLLER ADJUSTMENT

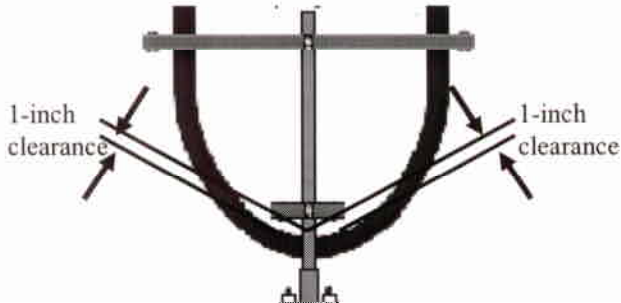

- Adjust the lowermost roller arm so that there is a one-inch clearance between the rollers and the compensating cable's loop.

NOTE: THE ADJUSTMENT OF THE LOWERMOST ROLLERS SHOULD BE PART OF A REGULAR MAINTENANCE/INSPECTION PROGRAM DURING THE ADJUSTMENT OF THE COMPENSATING CABLE'S LENGTH DUE TO SUSPENSION ROPE STRETCH.

BUFFER AND SAFETY TESTING

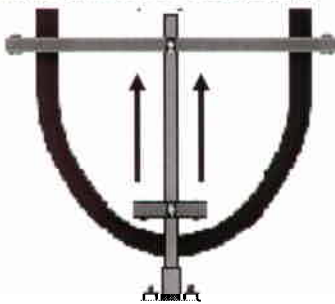

IMPORTANT NOTE:

DURING THE TESTING OF BUFFERS AND/OR SAFETIES WHERE IT IS LIKELY THE COMPENSATING CABLE LOOP WILL JUMP UPWARD SIGNIFICANTLY, IT IS IMPORTANT TO RAISE THE LOWERMOST ROLLERS TO THEIR MAXIMUM HEIGHT TO PREVENT DAMAGE TO THE SHALLOW SWAYLESS DEVICE.