

SPB INSTALLATION PROCEDURE: (4 STEPS)

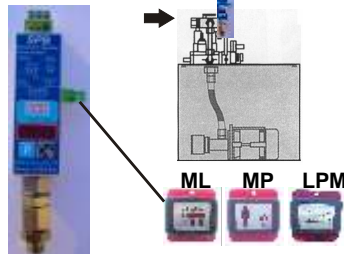

1 INSTALLATION:

Connect the sensor to the hydraulic circuit: Connect the electronic pressure sensor SPB replacing the mechanic pressure switch of the pump (manometer) for the electronic sensor or connect it in parallel by means of a "T" shaped coupling.



TYPE OF INSTALLATIONS:

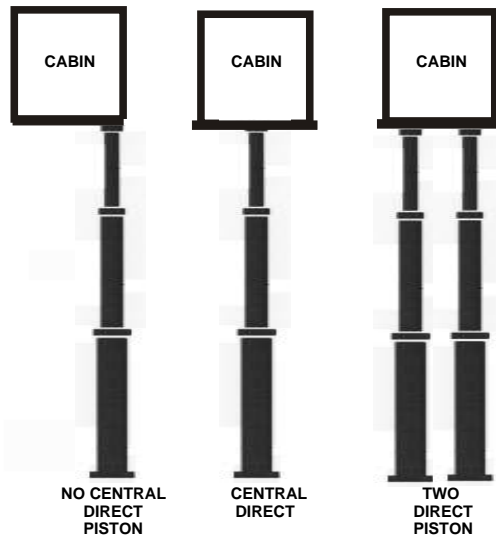

RECOMMENDATIONS:

In order to obtain a suitable accuracy of our pressure sensor we need that our elevator has **rollers** either on the top or on the bottom or on both, but **never guide rails** on both positions. This is so because if we have guide rails instead of rollers, "hooks" are always present, especially on **back-pack effect** elevators, (no central piston) and we will lose accuracy in our measurements.

2 CONNECTIONS:



SENSOR WIRING COLOUR

- + Vdc.....RED (+24 / +48)
- Vdc.....BLACK.
- DISABLING.....GREEN. (24 - 220 Vdc/ac)
- DISABLING.....BROWN. (24 - 220 Vdc/ac)
- RELAY 1.....WHITE.
- RELAY 1.....VIOLET.
- RELAY 2.....GREY.
- RELAY 2.....YELLOW.
- CABIN INDICATOR.....BLUE.
- CABIN INDICATOR.....PINK.

NOTE: Relays electrical ratings: 250Vac/ 3 A resistive

3 DISABLING OR BLOCKING VOLTAGE:

The disabling signal range is (24-220 V ac/dc);

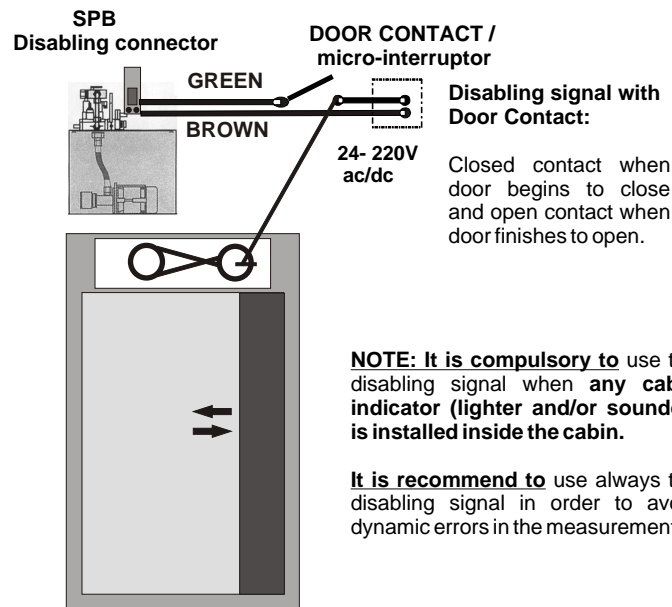

The SPB must continuously receive a blocking signal during all the time the lift is travelling, from the moment the doors are closing until the cabin gets on floor and the lift opens doors again.
NOTE: Continuously. (Voltage 24-220Vac/dc)

The display value will keep frozen after receiving this signal.

Connect the disabling or blocking wires (Green) and (Brown) using for example a (door contact micro) fed with voltage once

4 KEYS AND FIGURES:

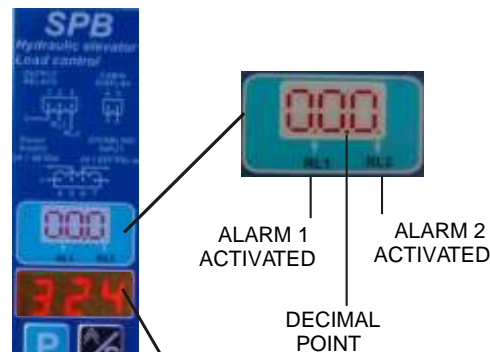

Note: The display remains switched off after 5 minutes of normal operation. Pressing any key the display value is visualised again.

PROGRAMMING KEY "P"

This key allows to go through the different menus in order to perform the settings and to introduce the lift parameters. Once introduced, by pressing the "P" key parameters are saved in eeprom (a non volatile memory to save data in case of power failure.)

EXIT KEY "S/▲"

It allows to leave the menus without saving data in eeprom. In the alarm menu, we go from one alarm to another without going through their parameters.

This key enables the user to increase the parameter values in each menu. It has two speeds; 0.1 by 0.1 or, if pressed on, two by two.

SPB PROGRAMMING PROCEDURE: (3 STEPS)



(Press the "P" key during 3 seconds to begin the programming procedure.)

1 ALARM VALUES:

The SPB has two alarms that can be configured by **HIGH** or by **LOW**.
HIGH=H= Relay normally open up to the programmed value, above this value close contact.
LOW=L= Relay normally closed up to the programmed value, above this value open contact.
Alarm 2 (RL2) : It is always assigned to **OVERLOAD**.
Alarm 1 (RL1) : It can be assigned to **FULL LOAD**.

CALIBRATING MODE:

AUTOMATIC: (Pressure Table Values).

We recommend to use this pressure table when our installation is the type of direct piston with rollers, so we are sure we do not have the "back pack effect".

Example of how to programm the different alarm values in bars per piston.

Note: For two parallel pistons the calculated value in bars must be divided by two.

The table below has been calculated taking normal person weight as 75 Kg. To convert any Kg units in Bar units we will do as follows;

Numerical example: If we want to put as alarm (633 Kg) and our piston diameter is 70 mm, the operation will be the next;

$$\frac{[\text{Alarm value in Kg}]}{[\text{Kg per bar and per diameter}]} = [\text{bars}]$$

$$\frac{[633 \text{ kg}]}{[38,48 \text{ Kg/bar}]} = [16,45 \text{ bars}]$$

MANUAL: LOAD (WEIGHT)

For a installation with **no direct central piston** as well as **no rollers**, we recommend to use known weights inside the cabin to make the calibration, for the full and overload situations. Once these weights are placed inside the cabin, we must introduce by means of the keys the corresponding values in bars for the two different alarm values.

For a **telescopic** installation (different diameters in the same piston) we recommend to use a known weight inside the cabin in the bottom and top floors. We observe the different results and calibrate the two alarm values accordingly.

2 ZERO CALIBRATION: "Tar"

Make the zero setting with empty cabin, selecting "YES". It is recommended to jump before inside the cabin in order to avoid any possible cabin "hooks" on the guide rails. After that, pressing the "P" key the equipment begins to flicker for 15 seconds to permit the installer to leave the cabin totally empty.

3 CABIN INDICATOR: "INDI"

"NO" = No indicator installed inside the cabin.

"PRO"=MICELECT progressive models (MP or LPM)

"BAS"=MICELECT basic indicator ML model or any lighter-sounder system powered by 24Vdc

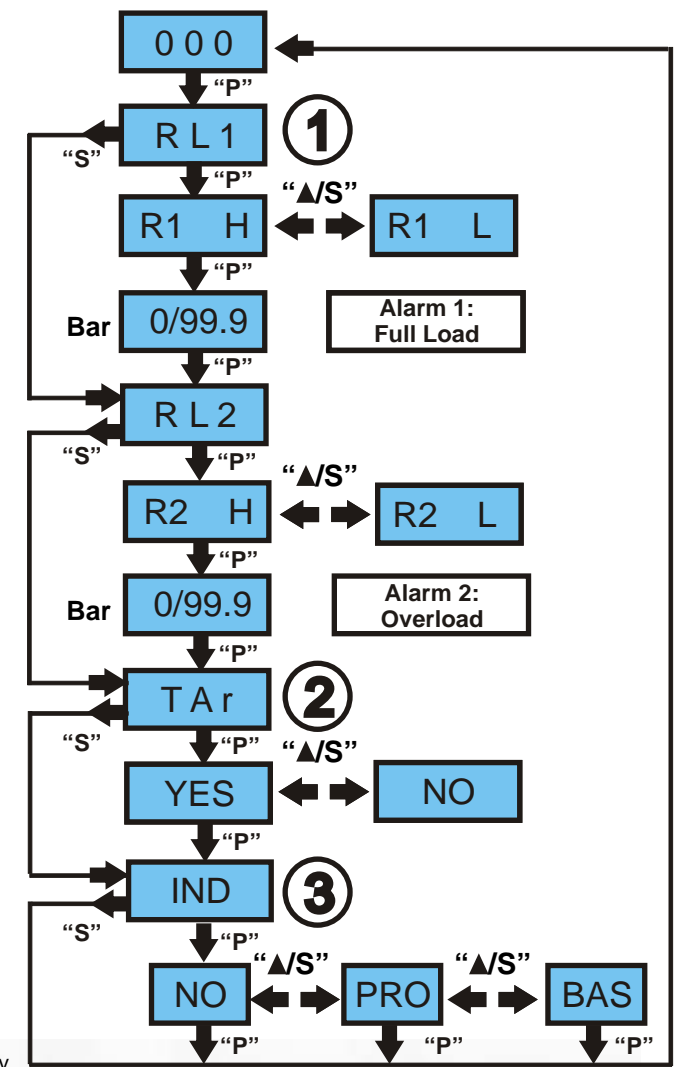

TABLE OF PRESSURES

KG. PER 1 BAR	28,27	38,48	50,26	63,61	78,54	95,03	113,09	132,73	176,71	201,06	
PISTON DIAMETERS											
PERSONS	KILOGRAMS	Ø60	Ø70	Ø80	Ø90	Ø100	Ø110	Ø120	Ø130	Ø150	Ø160
2	150	5,31	3,90	2,98	2,36	1,91	1,58	1,33	1,13	0,85	0,75
3	225	7,96	5,85	4,48	3,54	2,86	2,37	1,99	1,70	1,27	1,12
4	300	10,61	7,80	5,97	4,72	3,82	3,16	2,65	2,26	1,70	1,49
5	375	13,26	9,75	7,46	5,90	4,77	3,95	3,32	2,83	2,12	1,87
6	450	28,27	11,69	8,95	7,07	5,73	4,74	3,98	3,39	2,55	2,24
8	600	21,22	15,59	11,94	9,43	7,64	6,31	5,31	4,52	3,40	2,98
10	750	26,53	19,49	14,92	11,79	9,55	7,89	6,63	5,65	4,24	3,73
13	975	34,49	25,34	19,40	15,33	12,41	10,26	8,62	7,35	5,52	4,85
16	1200	42,45	31,19	23,88	18,86	15,28	12,63	10,61	9,04	6,79	5,97
21	1575	55,71	40,93	31,34	24,76	20,05	16,57	13,93	11,87	8,91	7,83

UNIT OF PRESSURE= BAR

ERROR CODES:

- ER1....No saved Data.
- ER2....Overload.
- ER3....Power Supply Low.

SOLUTIONS:

- ER1....Make again the settings.
- ER2....Pressure > 99.9 Bar.
- ER3....Check the Power Supply.

ENGLISH

MICELECT S.L. C/OTOÑO, 23 Parque Industrial "Las Monjas" 28850 Torrejón de Ardoz MADRID (SPAIN)

Tel: +34 91 660 03 47 Fax: +34 91 660 04 73 e-mail: micelect@micelect.com Internet: <http://www.micelect.com>

