



The Kellems® Mesh Grip Hanger Bracket (KHBRKT) provides a hitching point underneath the elevator car for one or two traveling cables being supported by Kellems mesh grips. Maximum hanging length of the traveling cables shall be 200 feet or less as required by the NEC (NFPA 70).

Installation

1. Locate the attachment point for the bracket underneath the car [Figure 1].

NOTE: Ensure that the attachment point for the bracket will allow: the traveling cable(s) to vertically hang down from the bracket with the cable loop perpendicular to the hoistway wall and the proper loop diameter.

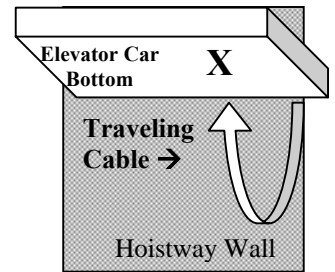

FIGURE 1

2. The bracket can be attached to the stringers placed twenty (20) inches apart or less on the underside of the car platform. Mark location of mounting holes on the stringers. Drill two (2) mounting holes for 1/2" bolts [Figure 2].

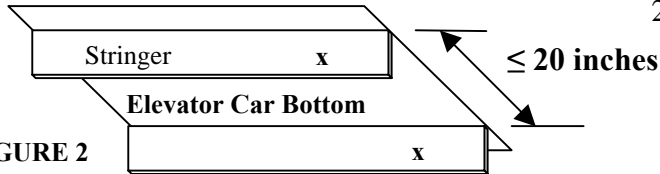

FIGURE 2

NOTE: Ensure holes are in plane with the traveling cable's loop.

3. Assemble the bracket shown using the length of strut, four (4) angle brackets, 1/2" x 1" bolts, hex nuts, lock washers and flat washers [Figure 3]. Hand-tighten only.

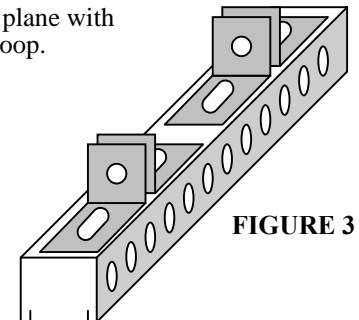

FIGURE 3

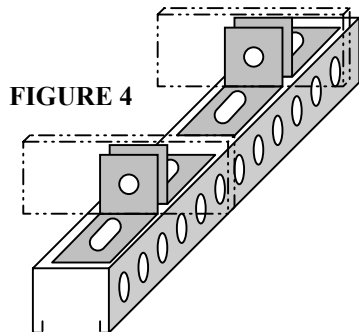

FIGURE 4

4. Securely attach the bracket to the stringers using the four (4) slotted angle brackets, 1/2" x 1 1/2" bolts, hex nuts, lock washers and flat washers [Figure 4]. Tighten all fasteners on the bracket.

5. With the bracket securely attached to the car, hang the Kellems® grips, already installed on the traveling cable(s), to the bracket using the two (2) 1/2" x 3 1/2" bolts, hex nuts, lock washers and flat washers [Figure 5].

NOTE: Ensure that there is at least one (1) inch of clearance between the cables.

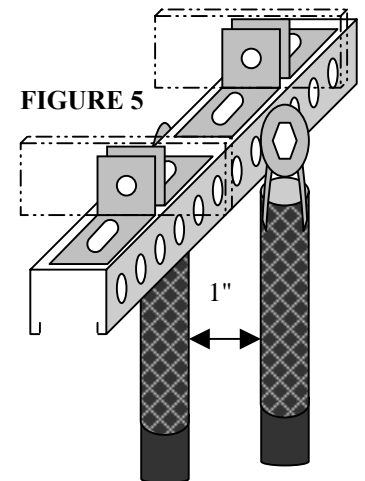

FIGURE 5

DEP-KHBRKT/001

Draka Elevator Products and the Draka Globe Design are trademarks of Draka Elevator Products, Inc. Kellems is a registered trademark of Hubbell, Inc.

© Draka Elevator Products, Inc.
All Rights Reserved
July 2003

Draka Elevator Products, Inc.
2151 North Church Street
P.O. Box 400
Rocky Mount, NC 27804
252-972-6000
877-DRAKA-EP (877-372-5237)
Fax: 252.972.6001