



### APPLICATION

When Draka EP dampening devices can not be installed as recommended by Draka EP, i.e., dampening devices can only be placed on one leg (car or counterweight side) of the Whisper-Flex® compensating cable, dampening devices are placed below the recommended three-foot above the cable loop level (due to short, compressed buffer heights), etc., the Roller Bar Kit can be used as an additional dampening device. The Roller Bar Kit is also designed to be easily adjustable to the height of the Whisper-Flex® compensating cable loop.

### TOOLS NEEDED

Rotary Hammer with 1/2" drill bit, 3/4" socket and open-end wrench, 13mm deep well socket and open-end wrench.

### ASSEMBLY

**Mounting Posts** - Gather two floor mount fixtures, two 15" rails, four spring channel nuts and four 1/2" x 1" hex bolts. Place two spring nuts at an end of each of the 15" rails. Fasten a floor mount fixture to the end of each 15" rail using the 1/2" x 1" hex bolts (Figure 1).

**Roller Section** - Attach a roller to the ends of the 9 1/2" rails using the four 3/8" flat washers and the hardware on the roller shaft (Figure 2).

Slide the mounting posts into the roller section, where the rail openings are on opposite sides (Figure 3). Adjust the height of the roller to approximately 1" above the bottom center of the loop (Figure 4). If necessary, the roller section can be flipped over with the roller on the bottom of the section to achieve this height (Figure 5). Using two 1/2" x 3" hex bolts, two 1/2" hex nuts and the four 1/2" flat washers; fasten the roller section to the mounting posts.

Center the assembled roller bar on the cable's loop and mark the four mounting hole locations on the pit floor. Using a 1/2" drill bit, drill four 1/2" holes, 2 3/4" deep. Hammer the anchors into the holes. Using the hex nuts and flat washers, bolt the roller bar to the pit floor.

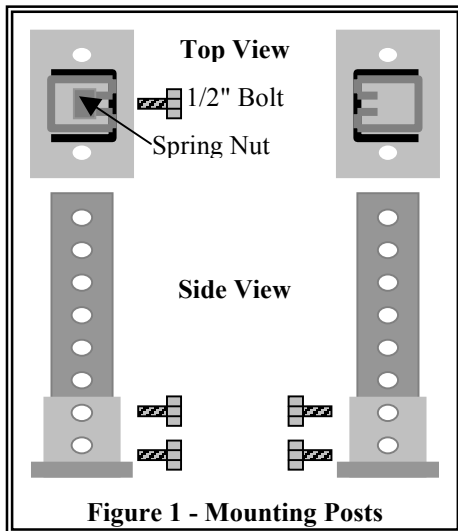

Figure 1 - Mounting Posts

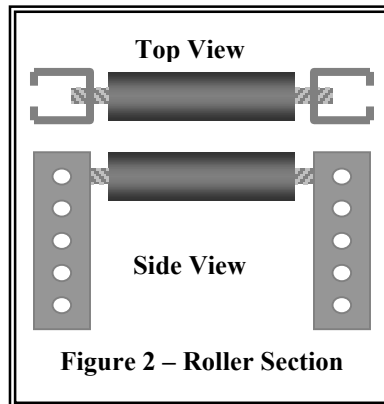

Figure 2 - Roller Section

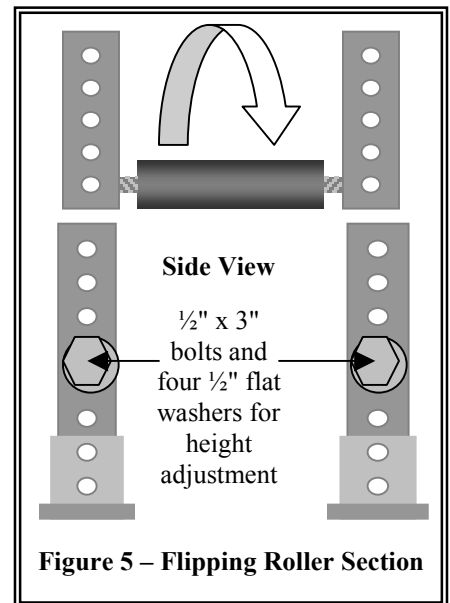

Figure 5 - Flipping Roller Section

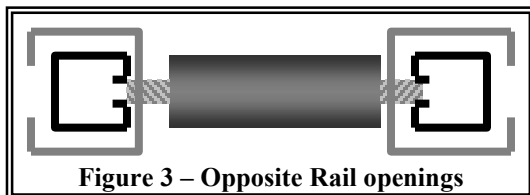

Figure 3 - Opposite Rail openings

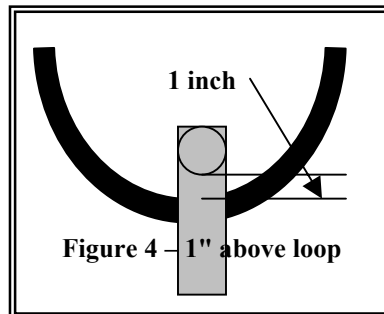

Figure 4 - 1" above loop

DEP-RLLR-BAR1/001

Whisper-Flex, Draka Elevator Products and the Draka Globe Design are trademarks of Draka Elevator Products, Inc.

© Draka Elevator Products, Inc.  
All Rights Reserved  
March 2003

Draka Elevator Products, Inc.  
2151 North Church Street  
P.O. Box 400  
Rocky Mount, NC 27804  
252-972-6000  
877-DRAKA-EP (877-372-5237)  
Fax: 252-972-6001