

The Super SwayLess™ Floor Mounting Bracket Kit (SSL-FMB-48) includes two stands designed to support two Super SwayLess Dampening Devices (WF-RDD2) to complete the installation of Whisper-Flex® Compensating Cable. Each stand fastens to the pit floor and can be adjusted to position the Super SwayLess devices at the recommended height.

ASSEMBLY

Each stand is composed of two identical bracket assemblies. Assemble them as shown in Figure 1. Each assembly contains one angle bracket, one 48" strut, three ½" bolts, three channel nuts and one base plate.

Secure the Super SwayLess device around the cable by threading the cable through the device or by removing the top roller above the open side of the Super SwayLess bracket, placing the cable in the center of the device, then reattaching the roller (Figure 2). The roller device can now be placed on two of the vertical bracket assemblies and fastened with four ½" bolts, lock washers, flat washers and hex nuts.

INSTALLATION

Once the Super SwayLess device is mounted, position the stand so that the vertical legs are to the inside of the loop where they can prevent side-to-side movement of the cable loop. **Ensure the Super SwayLess is parallel to the cable loop** (Figure 4). When the car is stationary, the cable should contact the two rollers closest to the center of the loop. As the car travels, the loop will become slightly wider and the cable will periodically contact the outer rollers thereby limiting cable sway and dampening oscillation.

Once the mounted device is in its correct position, mark holes on the pit floor using the base plate holes as a guide. Drill four ½" holes, 2¾" inches deep. Clear dust from hole. Hammer the wedge anchors into the holes. Place the rubber pad over the anchors, then fasten the Super SwayLess stand to the floor using ½" flat washers and hex nuts. Repeat the assembly and installation steps for the second bracket.

Adjust the height of the Super SwayLess device so that it is three feet above the bottom of the loop (Figure 3).

NOTE: THE SUPER SWAYLESS HEIGHT SHOULD NEVER EXCEED THE HEIGHT OF THE COMPRESSED BUFFER. SOME INSTALLATIONS MAY NOT HAVE ENOUGH ROOM TO PERMIT THE USE OF DAMPENING DEVICES THREE FEET ABOVE THE BOTTOM OF THE LOOP. IN THIS CASE, CALL DRAKA EP'S APPLICATION ENGINEERING DEPARTMENT AT 877-372-5237 OR 252-972-6000 FOR ASSISTANCE.

TOOLS NEEDED:
Hammer Drill w/ ½" drill bit
¾" Wrench

INSTALLATION TIME (est.): 15 minutes

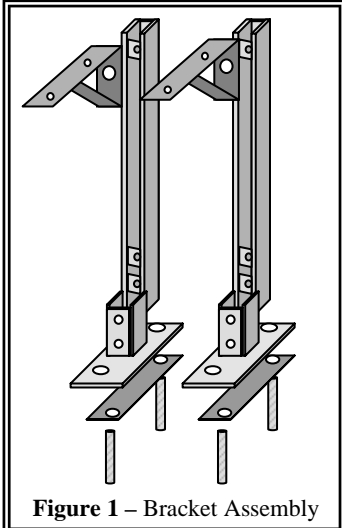

Figure 1 – Bracket Assembly

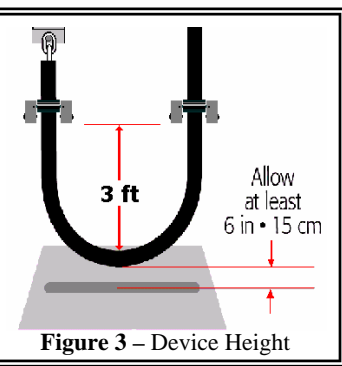

Figure 3 – Device Height

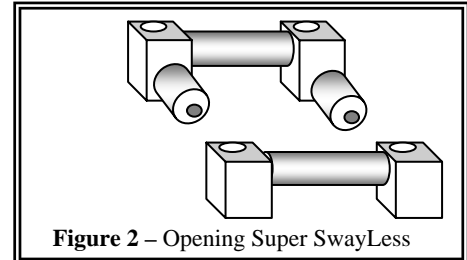

Figure 2 – Opening Super SwayLess

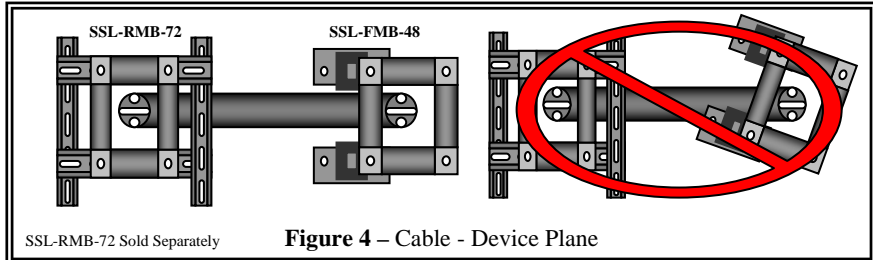

Figure 4 – Cable - Device Plane

DEP-SSLFMB48/003

Super SwayLess, Whisper-Flex, Draka Elevator Products and the Draka Globe Design are trademarks of Draka Elevator Products, Inc.

Draka Elevator Products, Inc.
2151 North Church Street
P.O. Box 400
Rocky Mount, NC 27804
252-972-6000
877-DRAKA-EP (877-372-5237)
Fax: 252-972-6001

© Draka Elevator Products, Inc.
All Rights Reserved
October 2005