

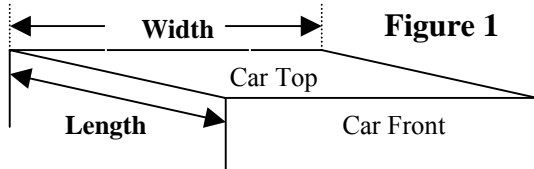

The TOC (Top-Of-Car) Toe-Board Kit is to be used in conjunction with the TOC (Top-Of-Car) Handrail Kit to provide protection to personnel working on car tops.

1) Dimensions

For front opening cars, measure the car's length and width. For front and rear opening cars, measure only the length.



2) Forming the Toe-Boards

Using the sections of flat rail listed in the table below, join the two sections together using two 3/8" bolts, lock washers and flat washers, so that the bolt heads are to the outside/threads pointing to the car's center (Figure 3). The formed toe-board should be equal to its respective dimension minus two inches to allow 1-inch clearance on all sides between the toe-board and the car top's edge (Figure 2).

KIT PART #	To FORM SIDE TOE BOARDS	To FORM REAR TOE BOARD
100-01TB	(1) 36" + (1) 48"	(1) 36" + (1) 48"
100-03TB	(2) 60"	(2) 60"
100-05TB	(1) 60" + (1) 72"	(2) 60"
100-07TB	(1) 36" + (1) 48"	N/A*
100-09TB	(2) 60"	N/A*
100-11TB	(1) 60" + (1) 72"	N/A*
100-13TB	(1) 48" + (1) 60"	(2) 36"
100-15TB	(1) 48" + (1) 60"	(1) 36" + (1) 48"
100-17TB	(2) 36"	(1) 36" + (1) 48"

* N/A – Front and Rear Opening Cars have no rear toe board.

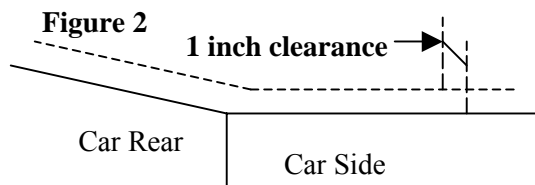

3) Fastening Support Angles

Fasten the 3" Support Angles to the outside of formed toe-boards using two 3/8" bolts, lock washers and flat washers, where the threads are pointing to the car's center (See Figure 3). The Support Angles should be placed as close to the ends of the formed toe-boards as possible and spread evenly between the ends with two feet or less of separation. Front

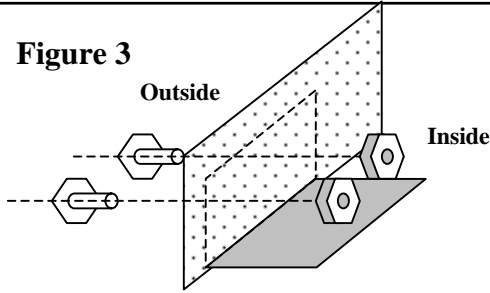

opening cars will have to leave 3" of clearance in the rear corners to place a corner angle (Figure 4).

NOTE: Two feet or less separation between support angles is required to meet performance requirement of 50 lbf laterally applied.

4) Attachment to Car Top

Fasten the support angles to the car top using two #10 screws, neoprene flat washers, and fender washers and maintain a 1" clearance from the car top edges (Figure 2).

NOTE: Ensure toe-board height is 4" with 1/4" clearance between the toe-board's bottom edge and the car top (Fig. 4).

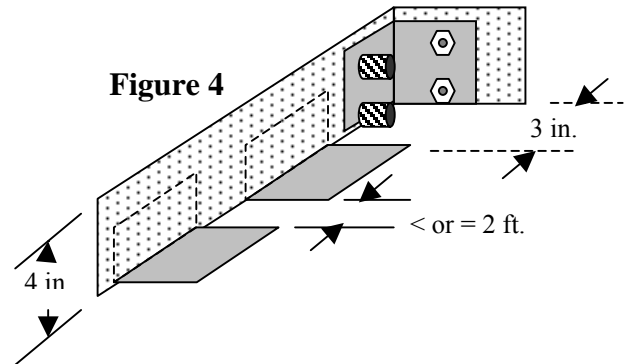

NOTE: Front and rear opening cars, skip Step 5.

5) Attaching Corner Angles

For front opening cars, two corner angles are included to attach the rear toe boards to the sides. Attach the corner angles to the inside of the toe-boards using four 3/8" bolts, lock washers and flat washers (Figure 4). Ensure threads point to car's center.

NOTE: The support and corner angles are the same part.

6) Final Installation Steps

- Tighten all fasteners securely.
- Ensure no part of the toe-board extends past the edge of the car top. One-inch clearance is recommended to allow some deflection of the toe board.

DEP-100-XXTB/0001

Draka Elevator Products and the Draka Globe Design are trademarks of Draka Elevator Products, Inc.

© Draka Elevator Products, Inc.
All Rights Reserved
February 2004

Draka Elevator Products reserves the right to improve, enhance and modify the features and specifications of our products without prior notification.

Draka Elevator Products, Inc.
2151 North Church Street
P.O. Box 400
Rocky Mount, NC 27804
252-972-6000
877-DRAKA-EP (877-372-5237)
Fax: 252-972-6001